



Recommended Practices for Supplemental Geometry

Release 1.0

November 1, 2010

Contacts:

Jochen Boy
ProSTEP iViP Association
Dolivostraße 11
64293 Darmstadt / Germany
jochen.boy@prostep.com

Phil Rosché
PDES, Inc.
5300 International Blvd.
North Charleston, SC 29418 USA
phil.rosche.ctr@ati.org

Table of Contents

1	Introduction.....	3
2	Scope.....	4
3	Fundamental Concepts	4
4	Supplemental Geometry	4
4.1	Linking the Supplemental Geometry to the file structure	4
4.2	Definition of the Supplemental Geometry.....	6
4.3	Linking PMI Data to Supplemental Geometry	7
5	Part 21 File Examples.....	8
Annex A	Availability of Implementation Schemas	9
A.1	AP214	9
A.2	AP203 2nd Edition.....	9

List of Figures

Figure 1 - A reference plane for a Datum as typical example for Supplemental Geometry	3
Figure 2 - Supplemental Geometry related to the Part Shape.....	5
Figure 3 - Axis placements as Supplemental Geometry defining tool targets.....	7
Figure 4 - PMI element referencing Supplemental Geometry	8

1 Introduction

When designing a part in a CAD system, geometrical elements are often created that do not belong to the actual, i.e. manufactured, shape of the part or assembly, but are used to either create other geometric shapes, or to carry additional information about the part or assembly.

Depending on the application context and the CAD system used, there are many terms for these elements, such as:

- supplemental geometry
- construction (constructive) geometry
- auxiliary geometry
- design geometry
- support geometry
- cosmetics
- reference geometry

It has been agreed to use the term “supplemental geometry” to relate to this capability. It is less ambiguous than the initially used “construction geometry”, and is also the term defined by international standards such as ASME Y14.41 and ISO 16792.

Definition of the term “supplemental geometry” according to ASME Y14.41:

“Geometric elements included in product definition data to communicate design requirements but not intended to represent a portion of the manufactured product.”

Supplemental Geometry elements typically are faces (e.g. cutting planes), curves (e.g. center lines) and points and coordinate system (e.g. tool targets). CAD systems may handle these in different ways, i.e. bound or unbound.

The main business needs for this capability to day are:

- The transfer of supplemental geometry elements that can be referred to by product manufacturing information (PMI), such as Geometric Dimensions & Tolerances (GD&T).
- The transfer of named axis placements as tool targets for downstream processes, such as NC programming, and coordinate measuring.

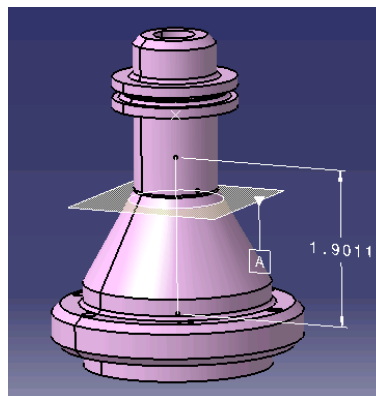

Figure 1 - A reference plane for a Datum as typical example for Supplemental Geometry

2 Scope

The following are within scope of this document :

- Transfer of geometric elements that are clearly identified as not being part of the manufactured shape of the part, including
 - bound and unbound faces and curves
 - cartesian points
 - axis placements

The following are outside of the scope of this document:

- Transfer of any properties attached to the supplemental geometry elements beyond the element name

3 Fundamental Concepts

The subtype of `shape_representation` used to collect the supplemental geometry elements (`constructive_shape_representation`) is defined in both AP214 and AP203e2. It limits the types of allowed geometry elements, and carries by itself the information that all enclosed elements are of a supplemental nature.

It is allowed to define more than one set of Supplemental Geometry elements, i.e. have several instances of `constructive_shape_representation` in a STEP file. This can for instance be the case to distinguish supplemental elements created to support PMI elements (e.g. a reference plane to which a datum is attached) from supplemental geometry created for other purposes.

The geometric elements used to describe the supplemental elements are taken from the usual geometric definitions used by both AP203 and AP214, defined in Parts 41 and 42, and the underlying AICs (511, 514,...).

4 Supplemental Geometry

The basic idea behind the definition of the Supplemental Geometry is to handle it not as a portion of the part shape, but as a separate “shape”, which is intended to provide additional information related to the part shape.

The definition of the supplemental geometry itself follows the usual pattern, with the notable difference that unbound geometric elements (such as an infinite planes) are allowed.

4.1 *Linking the Supplemental Geometry to the file structure*

The diagram given in Figure 2 below describes the structure to define supplemental geometry in relation to the actual part shape.

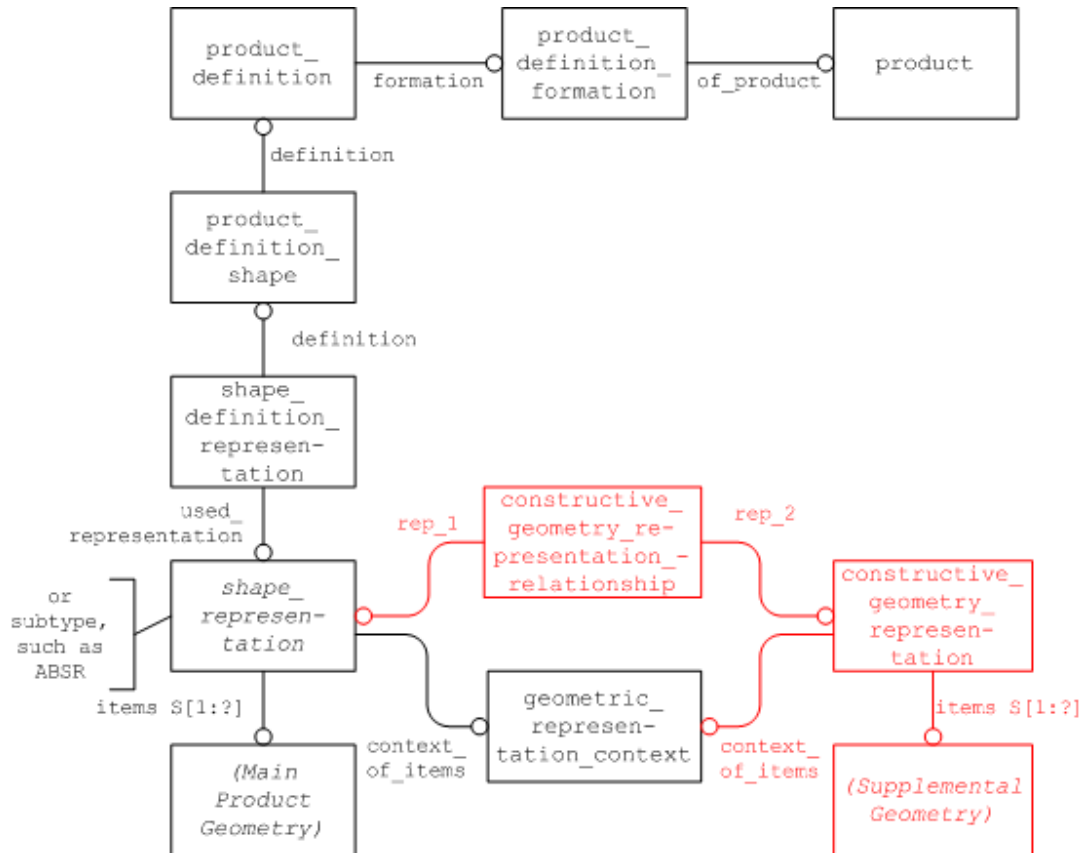

Figure 2 - Supplemental Geometry related to the Part Shape

Part21 Example:

```

#28=(GEOMETRIC_REPRESENTATION_CONTEXT(3)GLOBAL_UNCERTAINTY_ASSIGNED_CONTEXT((#26))GLOBAL_UNIT_ASSIGNED_CONTEXT((#16,#20,#24))REPRESENTATION_CONTEXT('','3D')));
#32=PRODUCT('sg1','','None',(#31));
#34=PRODUCT_DEFINITION_FORMATION('','None',#32);
#36=PRODUCT_DEFINITION('None','None',#34,#35);
#37=PRODUCT_DEFINITION_SHAPE('None','None',#36);
#38=ADVANCED_BREP_SHAPE_REPRESENTATION('',( #492),#28);
#39=SHAPE_DEFINITION_REPRESENTATION(#37,#38);
#564=CONSTRUCTIVE_GEOMETRY_REPRESENTATION('coordinate systems',( #494,#498,#502,#506),#28);
#565=CONSTRUCTIVE_GEOMETRY_REPRESENTATION_RELATIONSHIP('coordinate systems',$,#38,#564);
  
```

The specific subtype of shape_representation used to collect the supplemental geometry elements, constructive_geometry_representation, is defined in both AP203e2 and AP214 and is characterized as follows:

“A `constructive_geometry_representation` is a type of representation that is a collection of non-shape geometry that is used to support the definition of the geometry that is representing the shape of the part.”

The associated rules require that it shares the same geometric context as the shape of the part, and it needs to be related to the part's `shape_representation` via a `constructive_geometry_representation_relationship`.

4.2 Definition of the Supplemental Geometry

The supplemental geometry is defined in the same way as the usual geometry defining the manufactured part shape. All elements are collected in the set of items of the `constructive_geometry_representation` and shall be of type `placement`, `curve`, `edge`, `face`, `point`, `surface`, `face_surface` or `vertex_point`.

Depending on how the supplemental geometry is internally defined in the exporting CAD system, there are two significantly different ways how the detailed definition may look:

Unbound Supplemental Elements

In some systems, e.g. Siemens NX, supplemental elements such as reference planes or center lines are defined as unbound elements, i.e. planes or lines with infinite extent. The corresponding STEP entities to be used are `plane` (defined by point and face normal) and `line` (defined by point and direction).

Bound Supplemental Elements

Other CAD systems, e.g. CATIA V5, define supplemental elements with a default, limited size. A reference plane for instance is displayed as a rectangle with given width and height. The transfer of this information requires the full topological definition with `plane`, `edge_curves`, `edge_loop` and `face_surface`.

Handling of Bound vs. Unbound Supplemental Elements

Each CAD system shall export the Supplemental Elements in the way that it treats them internally. This guarantees an unambiguous data exchange for similar systems. When importing supplemental geometry into a CAD system that handles those elements in a different way than the exporting system, the recommendations are as follows:

- When importing bound elements into a system that usually handles them unbound, it is straightforward to use the underlying, unbound base elements (e.g. the `plane` for a `face_surface`), and omit the boundary definitions.
- In the opposite case, it is recommended that the importing system automatically creates and adds boundaries in a default size (e.g. dynamically derived from the model dimensions), which can later be adopted by the user, should a smaller or larger extent be desired.
- If these supplemental elements have a specific name, it shall be applied to the basic, unbound elements (i.e. `plane` or `line`) to guarantee it can be found by the importing system.

In addition to the geometric definition, supplemental geometry is also handled differently from a model structure point of view. Some CAD systems have designated containers or structural nodes where these elements are linked, other handled thus by assigning the supplemental elements to specific layers.

It was agreed that even while STEP supports layers (see Recommended Practices for Colors & Layers), these shall not be used to identify supplemental geometry, but the exporting system shall always map it to the structure defined in section 4.1 of this document.

Points and Axis Placements

Since points and axis placements have no extent by definition, they are always transferred in the same way, as elements in the set of items of the `constructive_geometry_representation` defining the supplemental geometry.

Axis placements shall be mapped to (empty) coordinate systems with the name as given in the STEP file by the target system (see Figure 3).

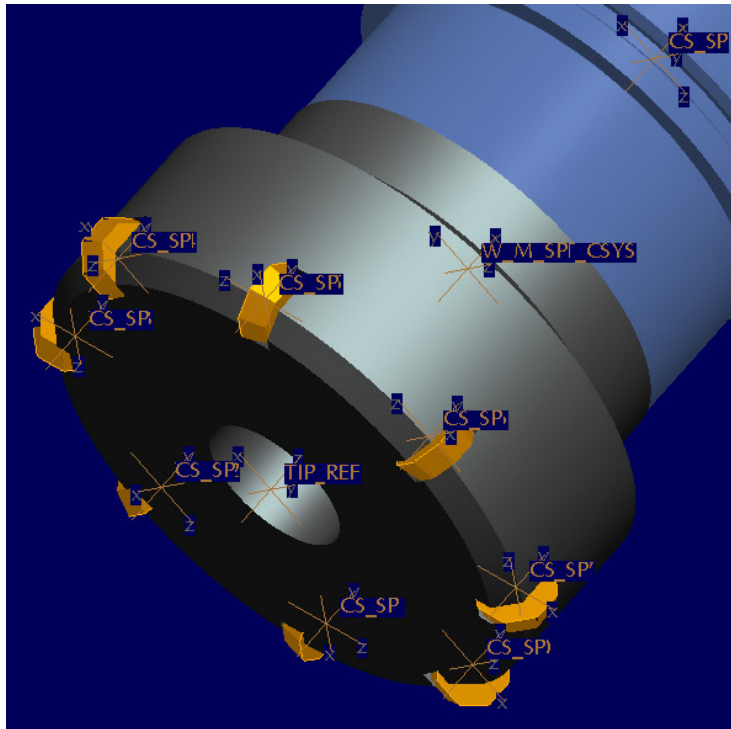

Figure 3 - Axis placements as Supplemental Geometry defining tool targets

4.3 Linking PMI Data to Supplemental Geometry

One of the main usage scenarios for the transfer of supplemental geometry is that it is used as references for PMI data, such as datums or dimensions.

In this case, the basic structure to define the PMI elements themselves and their linkage to the geometry stays the same as when defining PMI elements for the manufactured part shape, only the elements referenced by the `geometric_item_specific_usage` are now supplemental geometry elements, as show in Figure 4 below.

Note that the `shape_representation` (or subtype) which contains the main product geometry, the `constructive_geometry_representation` for the supplemental geometry and the `draughting_model` collecting the annotations all need to share the same `geometric_representation_context`.

Depending on the approach used to present the PMI information, the `shape_aspect` used for its definition needs to be of the appropriate type:

- for Polyline Presentation, it needs to be a plain `shape_aspect` (compare Recommended Practices for Representation and Presentation of PMI, Figure 43)
- for Semantic Presentation, it needs to be the appropriate subtype of `shape_aspect`, e.g. `datum`.

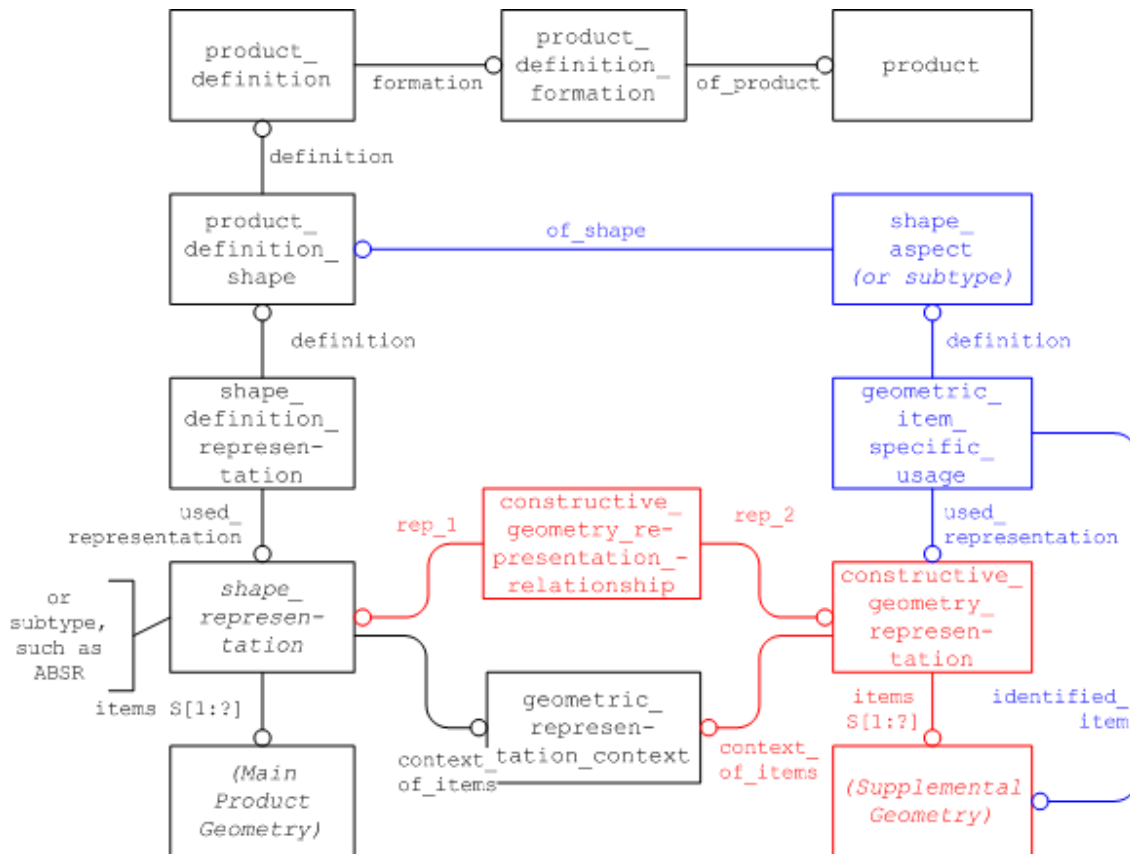

Figure 4 - PMI element referencing Supplemental Geometry

5 Part 21 File Examples

STEP Files relating to the capability described in this document will be made available in the public STEP File Library on the CAx-IF homepage; see either <http://www.cax-if.de/library/> or <http://www.cax-if.org/library/>.

The files will be based on current schemas for both AP203 Edition 2 and AP214, and will have been checked for syntax and compliance with the Recommended Practices.

Annex A Availability of Implementation Schemas

A.1 AP214

The AP214 schemas support the implementation of the capabilities as described. The schemas can be retrieved from:

- IS Version (2001) – http://www.cax-if.de/documents/ap214_is_schema.zip
- 3rd Edition (2010) – http://www.cax-if.de/documents/AP214E3_2010.zip

A.2 AP203 2nd Edition

The long form EXPRESS schema for the second edition of AP203, can be retrieved from:

- http://www.cax-if.org/documents/AP203E2_November_2008.exp

Note that the first edition of AP203 is no longer support in the Recommended Practices.